

AWO
Combination Hydraulic Water Level and Overflow Assembly

Function:

Flush, wall mounted, non-electric combination hydraulic water level control with built-in level adjustment and overflow drain. Automatically fills small to medium-sized pools and drains overflow water through a built-in adjustable drain.

Specification:

Construction shall be cast bronze frame with DEFO impact resistant stainless steel cover and moulded plastic enclosure. Overflow drain assembly shall be brass, copper and extruded plastic fitted with moulded plastic quick fill valve.

Options: (Add suffix)

- B - brass cover plate
- Q - chromed frame
- V - vandal resistant fasteners and wrench kit

Note:

- 1-AWO-050 maximum recommended water pressure is 25-30 PSI at 5 GPM.
- 2-AWO-100 maximum recommended water 35 PSI at 9 GPM.
- 3-Must be installed with a backflow preventer.
- 4-W1 dimension is factory set water level

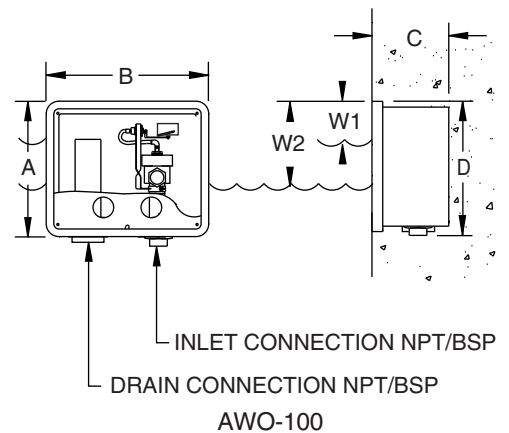
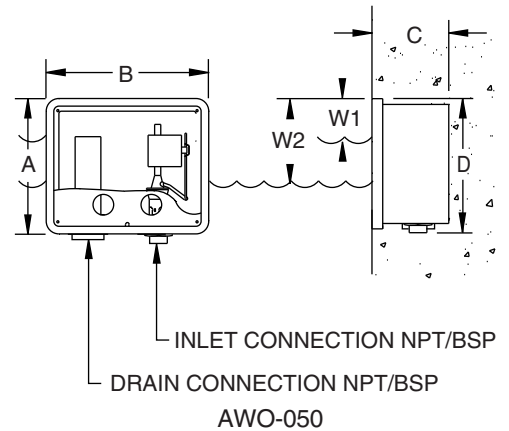
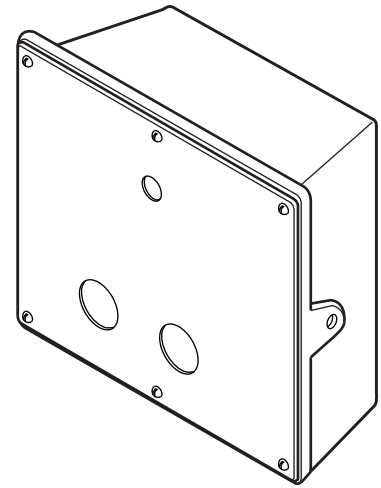

Dimensions

DEFO no.	inlet conn. (npt/bsp)	drain conn. (npt/bsp)	a dim.	b dim.	c dim.	d dim.	w1 dim.	w2 dim.
AWO-050	1/2"	2"	10"	12"	5 1/2"	11 1/2"	2 3/8"	3 5/8"
AWO-100	1"	2"	10"	12"	5 1/2"	11 1/2"	1 3/4"	3"

01/01/00