

Function

Flush, wall mounted, non-electric hydraulic water level control with built-in level adjustment automatically fills small fountains.

Specification

Construction shall be cast bronze frame with DEFO impact resistant stainless steel cover and moulded plastic enclosure. Brass and stainless steel fitted with moulded plastic quick fill valve.

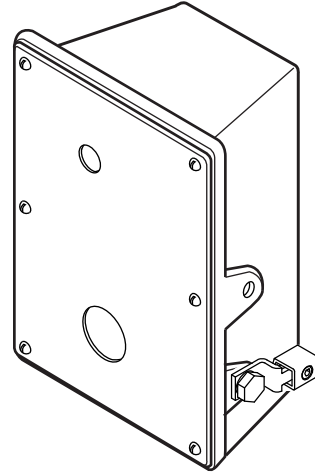

Option

B - brass cover plate

Notes

1. Must be installed with a backflow preventer.
2. W1 dimension is factory set water level

part no.	inlet ^{n.p.t./} b.s.p.	W1	W2	recommended water pressure
ACX050	1/2"	2 3/8"	3 5/8"	maximum 25-30 psi at 5 gpm
ACX100	1"	2"	3 1/4"	maximum 35 psi at 9 gpm

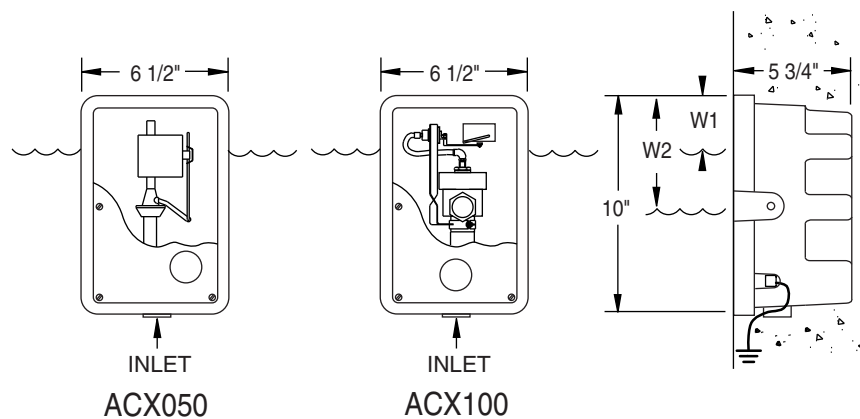

PROPRIETARY AND CONFIDENTIAL

THE INFORMATION CONTAINED IN THIS DRAWING IS THE SOLE PROPERTY OF CRYSTAL FOUNTAINS. ANY REPRODUCTION IN PART OR AS A WHOLE WITHOUT THE WRITTEN PERMISSION OF CRYSTAL FOUNTAINS IS PROHIBITED.

SHOP DRAWING
ACX-D101

www.crystalfountains.com

Crystal Fountains

**LIGHT DUTY HYDRAULIC
WATER LEVEL SENSOR**

SERIES

ACX

REV.

B

TEL. (905) 660-6674

FAX. (905) 660-6916

10.30.2003